

Door drive & car doors MOD310 QK11 C

Ref : MOD310 QK11 C version 2 **Door Drive**

The **FERMATOR** Group factory, Ets **PEIGNEN** are pleased to present a new renovation kit for QKS11 C operators.

COMPACT and **STURDY** this new kit will help You renovate your lifts.

Before

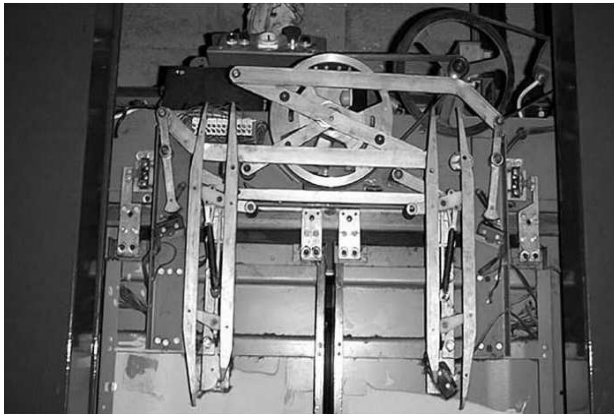

After



Features

- * Choice of renovation level, **total or partial**
- * **No prior work** required to the car fronts
- * Existing **car fronts** and header **preserved**
- * **Overall dimensions** similar to the original operator
- * **Total compatibility** with existing landing doors
- * Lift returned to service within **48 hours**
- * Latest generation of **VVVF**
- * Total weight of the new cabin door less than **100kg**
- * Flexible and very **adaptable**
- * Drive trough a **linear belt**
- * Fewer moving parts
- * Fewer electrical contacts
- * Factory assembled and **100% Quality Control**

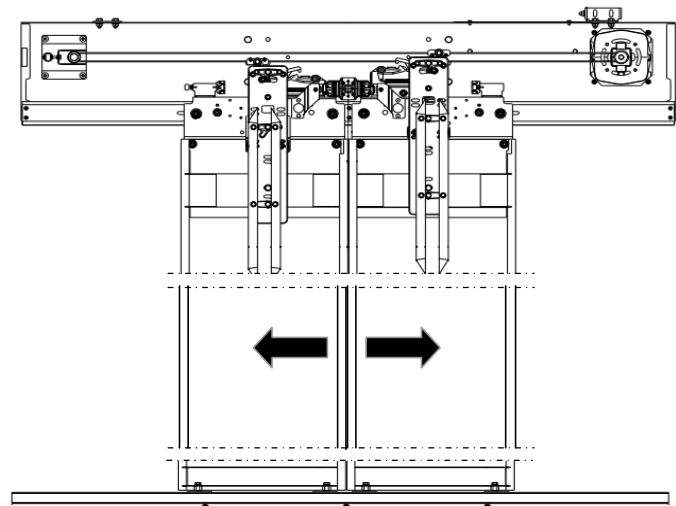

DOOR MOD310 QK11 C

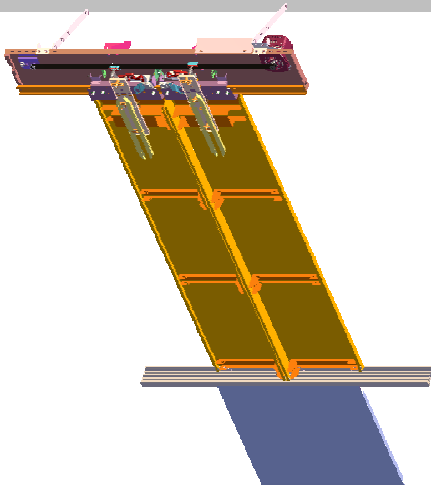

Principle: Single rail door drive, 2 panel, central opening. VVVF control. Can be used with the existing door panels or new panels.

Objective: The MOD310 door system replaces existing car doors with QKS11 operators with crank arm, belt or chain driven

STANDARD DIMENSIONS				NON STANDARD DIMENSIONS *				
BKE	700	800	900	BKE	1000	1100		
HKE	1900	2000	2100	HKE	2200	2300	2400	2500

* nous consulter

A Complete renovation **B** Partial renovation **C** Express renovation

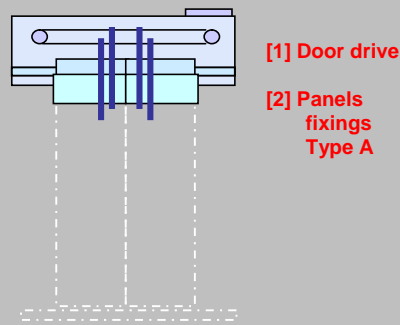
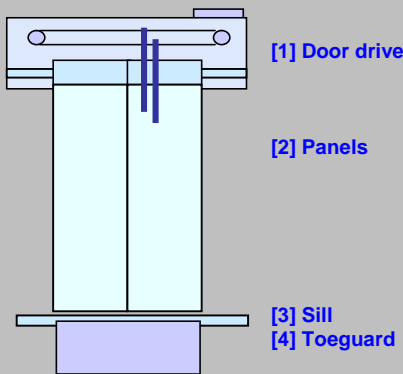

- [1] Door drive (without panels)
- [2] QKS8 adaptation
- [3] QKS11 adaptation
- [4] V10 adaptation
- [4] fixing kit on car roof
- [5] Double clutch
- * complete KIT without any option

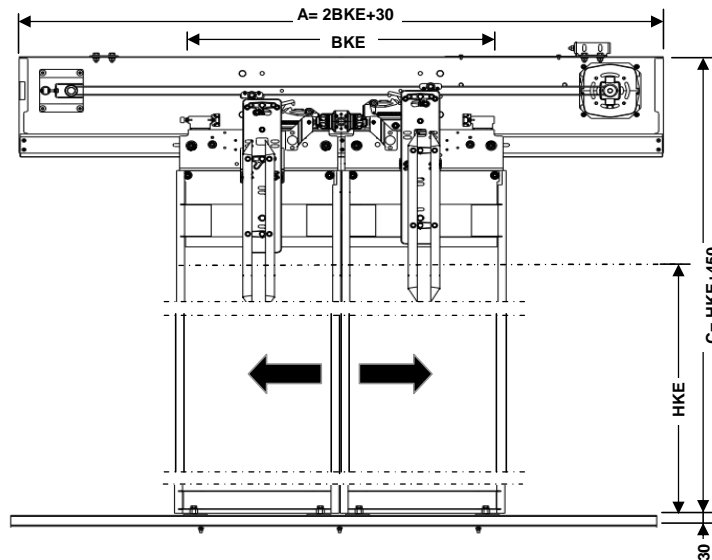

GLOBAL LIFT EQUIPMENT LTD
 H42/43 Ashmount Enterprise Park, Flint, Flintshire, CH6 5YL.

Tel: 01352 735400 Fax: 01352 735733
 Email: sales@global-lift.com Website: www.global-lift.com